

FG220 4ZV

/ TOP AND BOTTOM FLAT FINISHING MACHINE

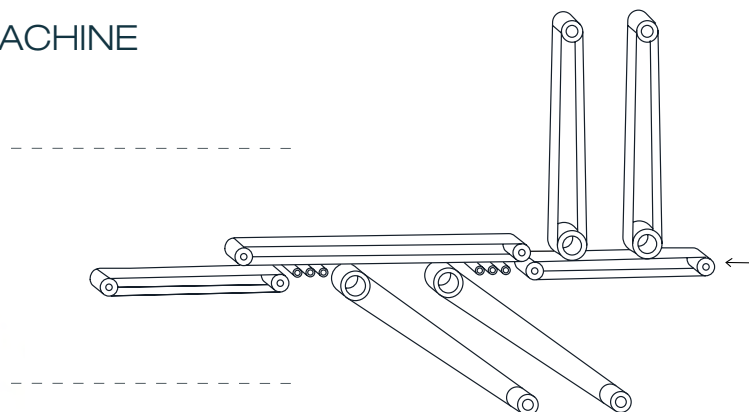

DEMONSTRATION VIDEO



OVERVIEW

__ Finishes tubes and bars on 2 sides simultaneously. Complete polishing of the 4 sides of the square tube in 2 passes only

__ Independent work of all abrasive stations. Possible to operate only one side

__ Fixed working height helps the work on long tubes and bars without having to adjust roller tables

TECHNICAL SPECIFICATIONS

working capacity (mm)	220x200
feeding speed (m/min.)	4-15
feeding motor (kW)	0.37 (x3)
abrasive belt speed (m/s)	10-25
abrasive belt dimensions (mm)	220x2200 (x4)
abrasive belt motor (kW)	5.5 (x4)
conveyor belt motor (kW)	0.25 (x3)
consumption (A)	44
dimensions (mm)	3990x1370x2110
weight (kg)	2570

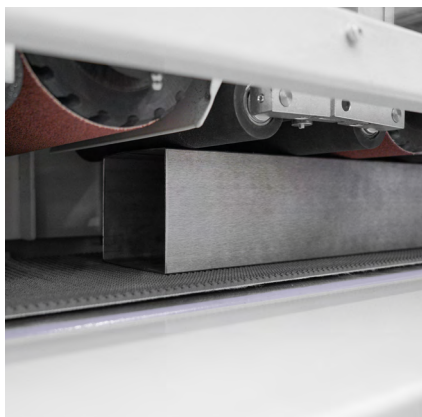

__ 2x faster finishing process on flat bars and rectangular tubes



__ 2 upper + 2 lower abrasive belt stations



__ independent thickness regulation for upper and lower heads