

MLW200

/ ROUND TUBE WET FINISHING MACHINE

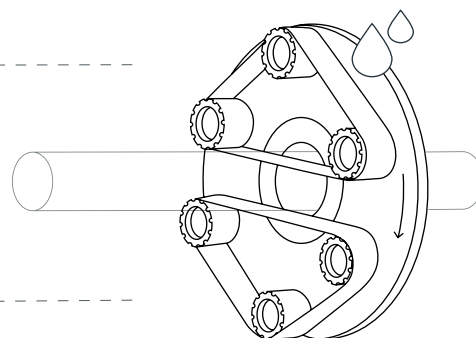

TECHNICAL SPECIFICATIONS

diameter capacity (Ø mm)	20-205
feeding speed (m/min.)	manual or 1-4
abrasive belt speed (m/s)	10-25
abrasive belt dimensions (mm)	70x1240 (2x)
abrasive belt motor (kW)	7.5
wheel motor (kW)	4
consumption (A)	28
dimensions (mm)	2380x1590x1450
weight (kg)	1440

DEMONSTRATION VIDEO



MINIMUM BEND CHART



STANDARD EQUIPMENT

- Blocking system for wheel rotation
- Foot pedal for belts opening and wheel unblocking
- Manual filtration system

AVAILABLE ACCESSORIES

- Touchscreen control on independent unit with program storage
- Automatic feeding system
- Photocells for automatic belts opening
- Automatic filtration system



optimized for large diameters and long tubes with minimal vibration



touchscreen on mobile, independent unit (optional)

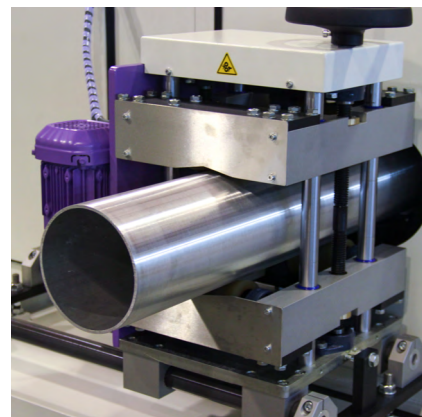

possibility to save programs and define specific areas to be finished