

# DM1100 Z2C EVO

/ DEBURRING AND EDGE ROUNDING MACHINE

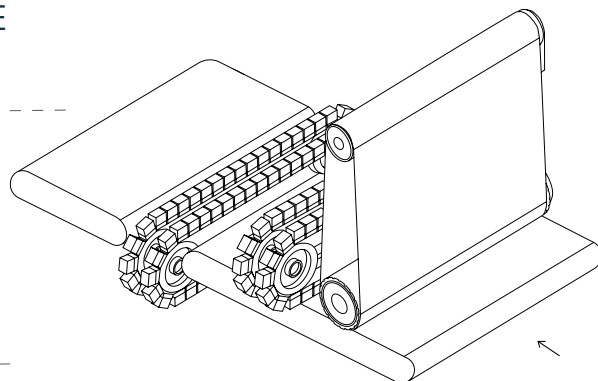

## TECHNICAL SPECIFICATIONS

working capacity (mm)	1100x120
feeding speed (m/min)	0.6-3.2
abrasive belt speed (m/s)	8-22
crossbelt speed (m/s)	2-8
feeding motor (kW)	0.18 (3x)
abrasive belt dimensions (mm)	1100x2200
abrasive + crossbelt motor (kW)	18.5 + 3 (4x)
consumption (A)	62
dimensions (mm)	3560x2320x2300
weight (kg)	4900

## DEMONSTRATION VIDEO



## OVERVIEW

\_\_ Burr removal and smooth edges on both sides in one single pass of parts cut by punching, shearing, laser or plasma

\_\_ This machine can process small parts, single side, with dimensions down to 50x50mm

\_\_ Designed so that it is easy to access the deburring units and main mechanical elements in case of machine cleaning and maintenance

\_\_ All covers open completely

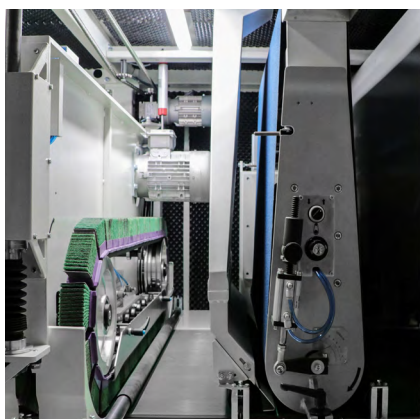

\_\_ upper deburring and edge rounding station

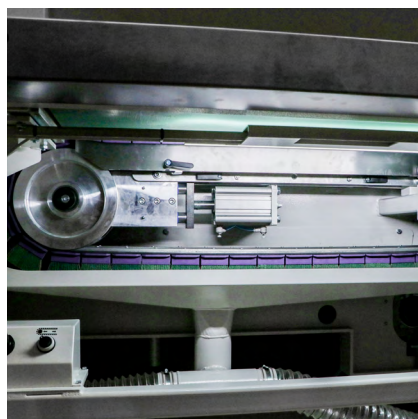

\_\_ lower edge rounding station



\_\_ small parts processing option and parts return system