

MP100

/ ROUND TUBE MIRROR POLISHING

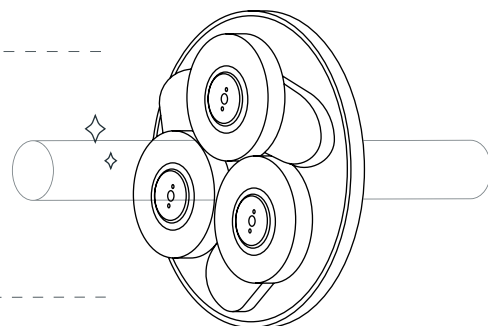

TECHNICAL SPECIFICATIONS

max. diameter (Ø mm)	114
feeding speed (m/min.)	manual or 1-3
polishing wheels speed (m/s)	up to 35m/s
polishing wheels dimension (mm)	Ø130-240 (x6)
polishing wheels motor (kW)	5.5
wheel motor (kW)	0.37
consumption (A)	22
dimensions (mm)	1100x1200x1550
weight (kg)	420

DEMONSTRATION VIDEO



STANDARD EQUIPMENT

- Polishing wheels inverter
- Triple foot pedal: polishing wheels automatic opening/closing + activation of polishing soap
- Digital Ammeter
- Automatic feeding system

MINIMUM BEND CHART



AVAILABLE ACCESSORIES

- Liquid compound with spray gun including a pressurised tank with 45l capacity



__ planetary polishing system that consists on three planetary polishing wheels wich rotate around the tube applying high pressure

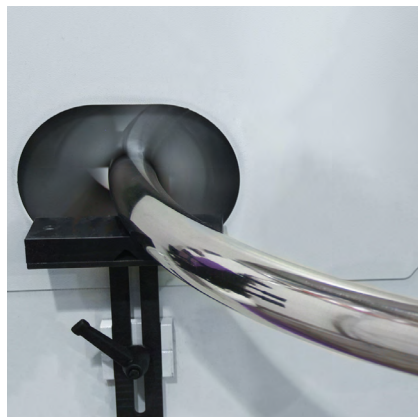

__ feeding units easily removable for bent tube polishing

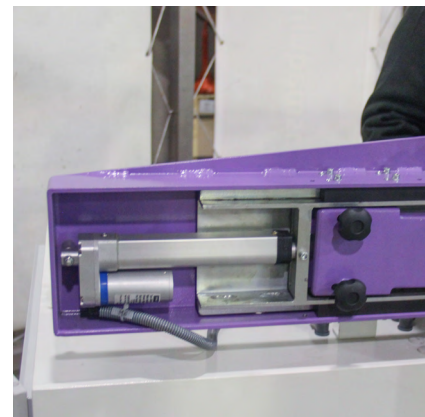

__ pneumatic system for automatic soap applying