

# DM1100 CC

/ DESLAGGING AND EDGE ROUNDING MACHINE

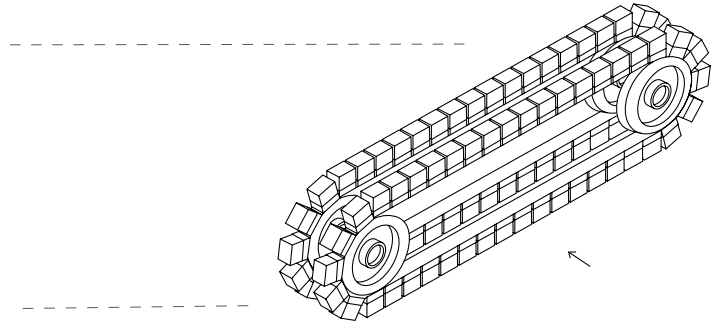

## DEMONSTRATION VIDEO



## OVERVIEW

\_\_ Designed for slag removal and edge rounding of plasma and oxy-fuel cut parts

\_\_ Two-stage process combining SILVER HAMMER and GREEN FLEX technologies

\_\_ Counter-rotating crossbelts provide complete edge coverage in all directions

\_\_ Clean and consistent results for real production environments

## TECHNICAL SPECIFICATIONS

working capacity (mm)	1100x50
feeding speed (m/min.)	0.6-3.2
crossbelt speed (m/s)	2-8
crossbelt motor (kW)	4x3
total power (kW)	12.4
consumption (A)	21
dimensions (mm)	1110x3720
weight (kg)	2000



\_\_ fast consumable change



\_\_ simple machine adjustments

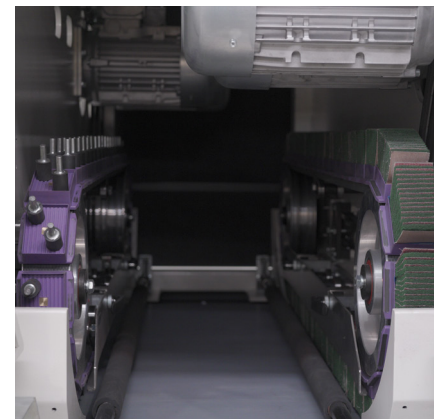

\_\_ flexible crossbelt technology